

# An Iterative Decision-based Technique for finding Topologically- feasible Solution Sets quickly

**Brian Prasad and Jeff Rogers**  
Parker Hannifin Corporation  
Aerospace Group  
Control Systems Division—Irvine, CA

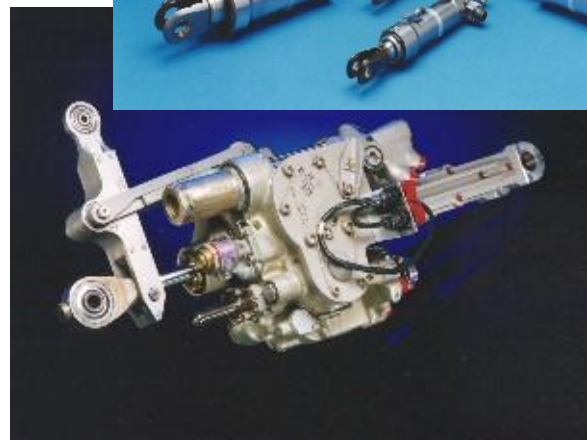

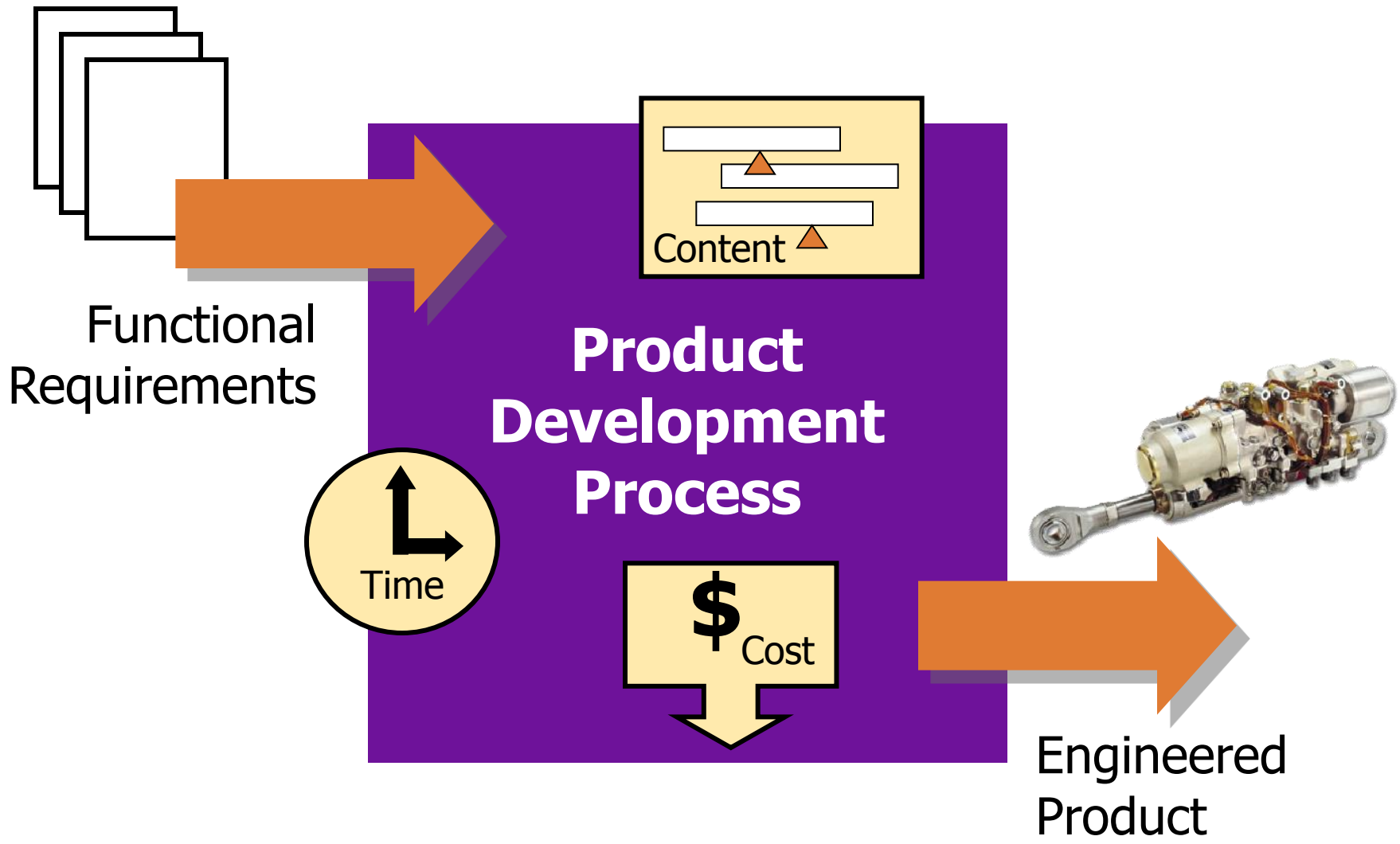



# Product-development process

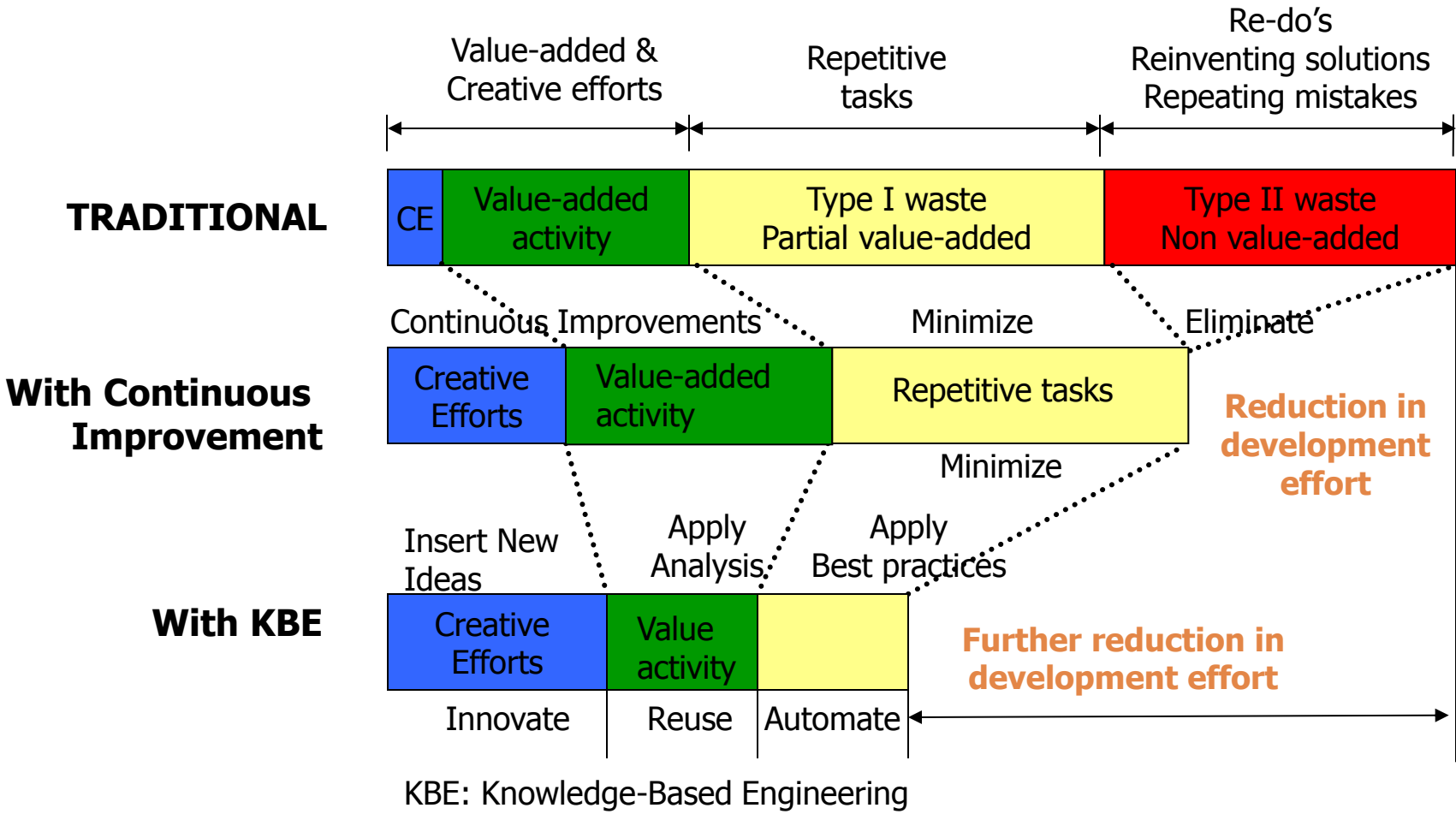

# Typical design scenario

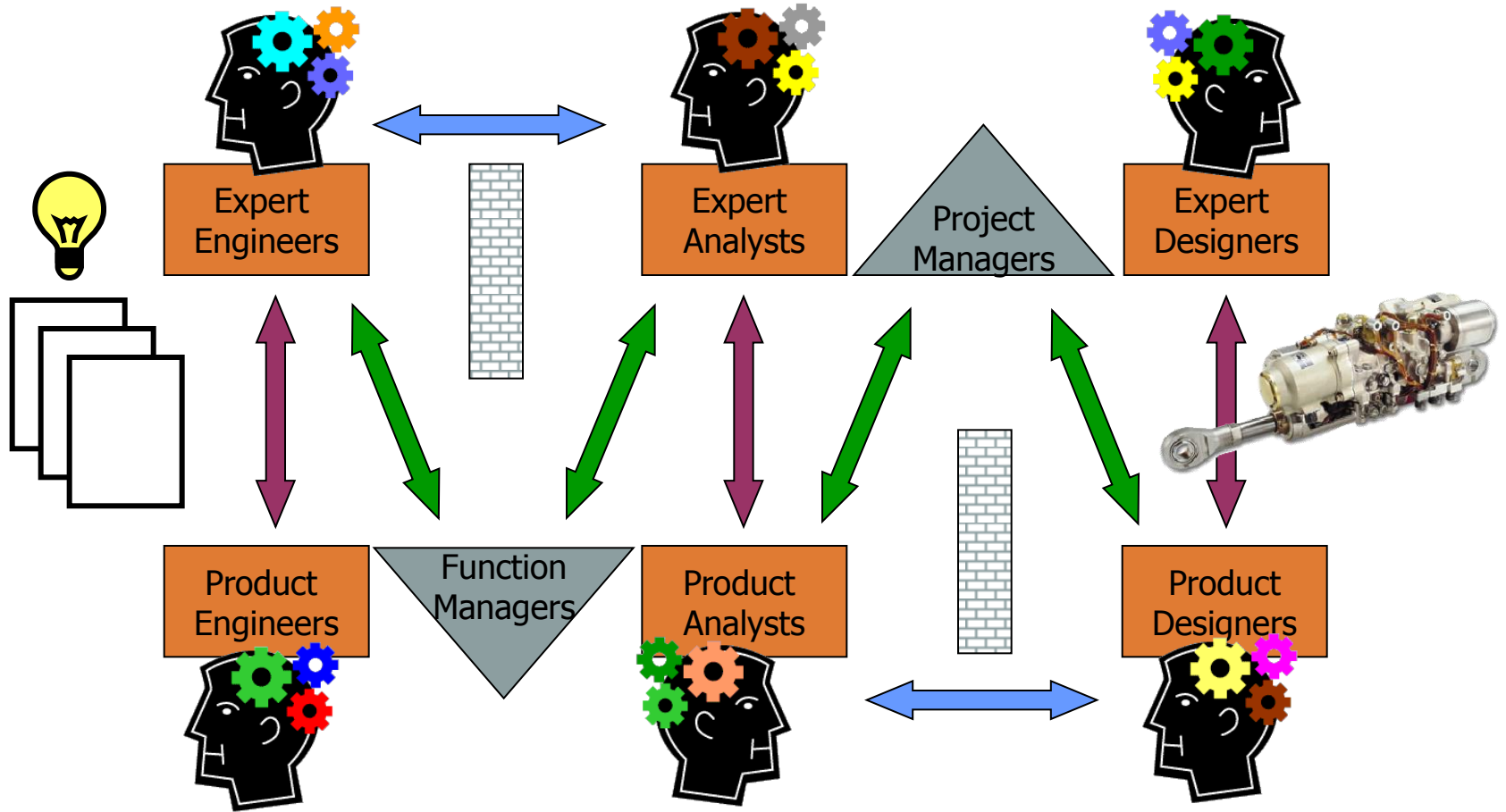

# What's wrong with this?

- Knowledge is fragmented
- Subject matter experts (SME) often scarce and busy
- Less uniformity and consistency
- Time-intensive, manpower dependent
- When people retire, information is lost
- Often design is done via trial and error—  
case-based reasoning

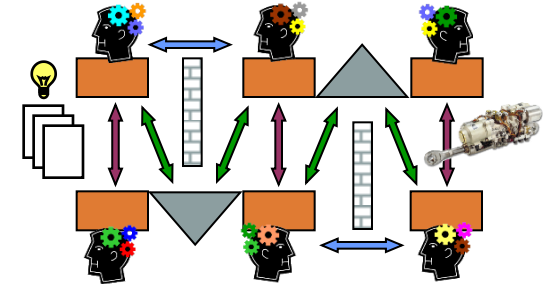

# Knowledge-centric approach

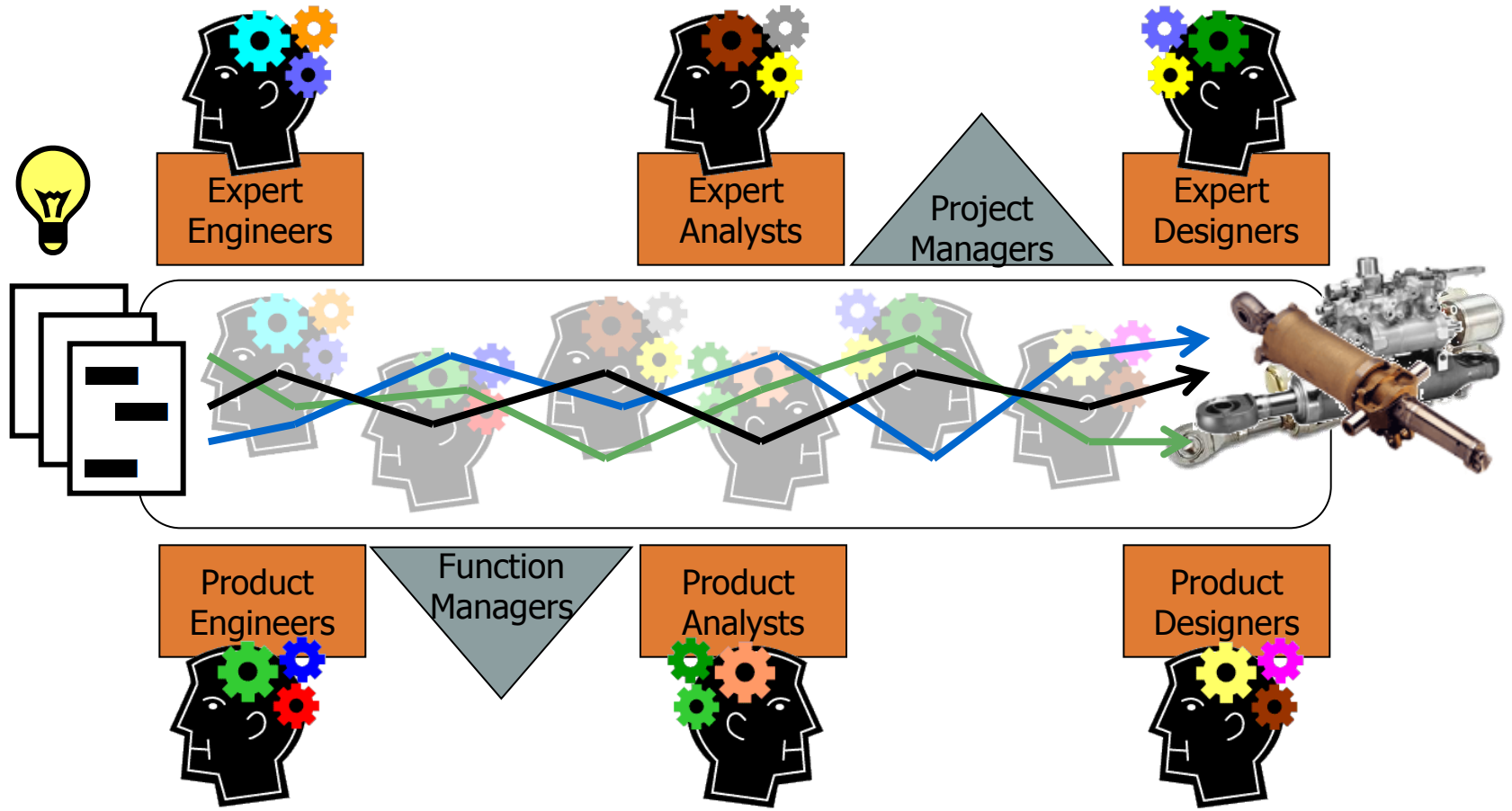



# Enrichment of knowledge...

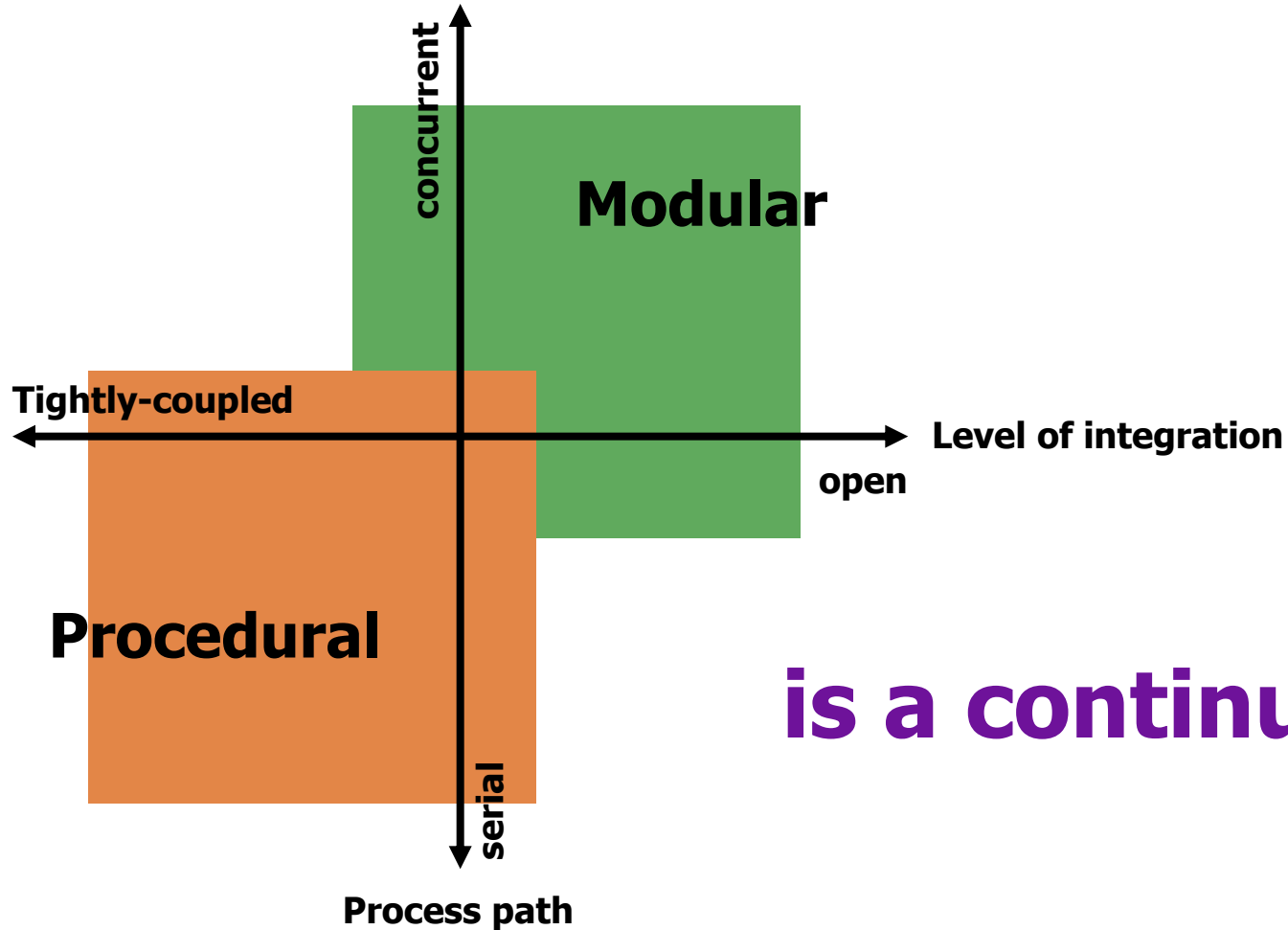

**is a continuum**

# Let's consider this situation

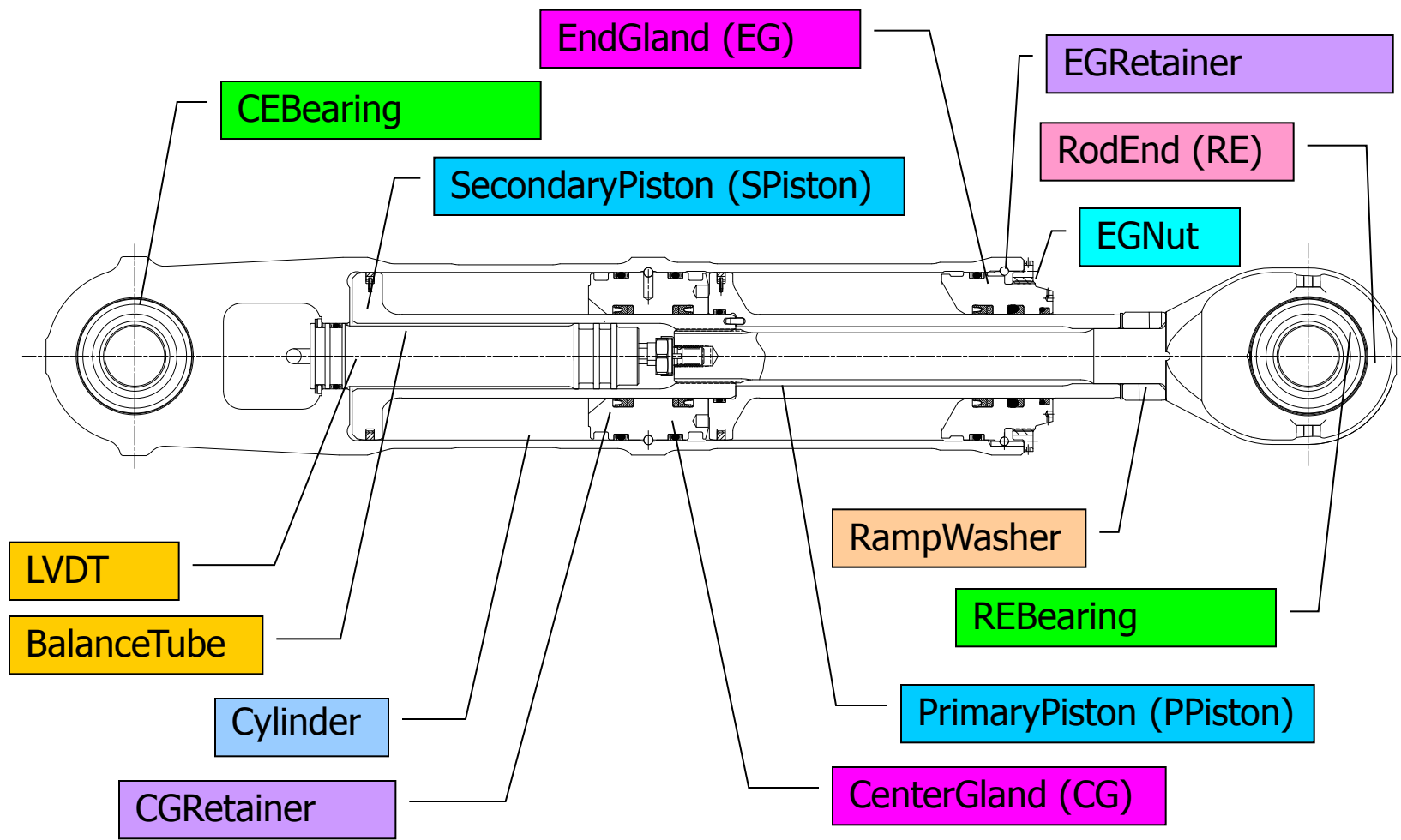

# Serial, tightly-coupled KBE system

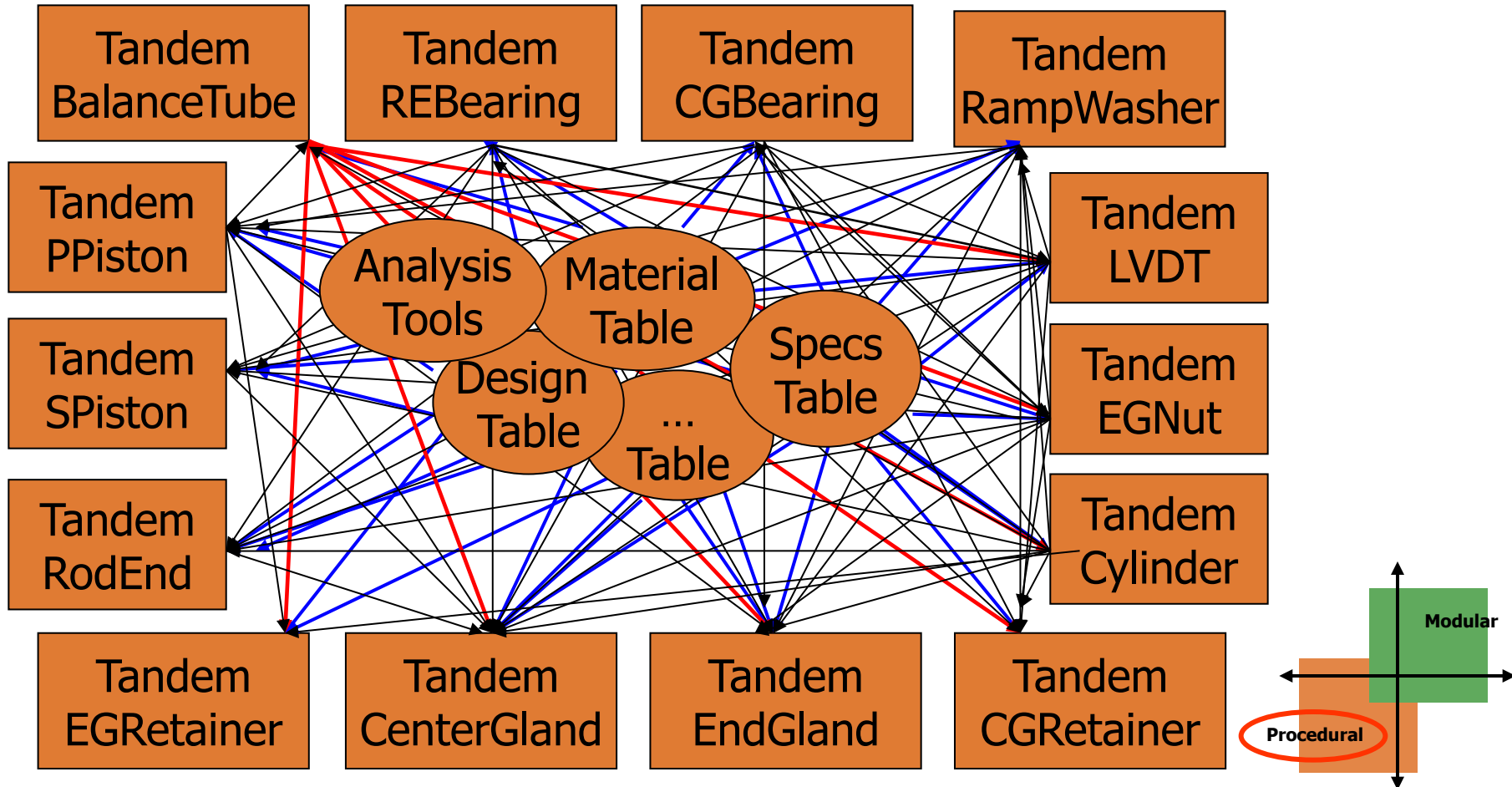

# Drawbacks of procedural process

- Part and product specific
- Hard-coded interfaces
- Cumbersome to maintain
- Incompatible API's
- External parameter linking issues
- Very sensitive to interface changes (parameters, rules, features)
- Expansions are complex and error prone
- Inflexible

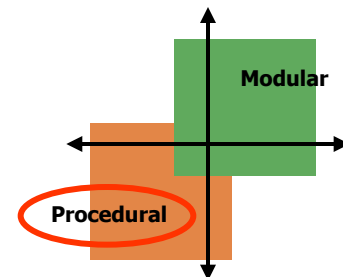

# Modular, rule-based KBE system

An assembly of parametric parts, where dependence of one part to another is controlled by a “control structure logic”—whose primary function is to link relationships and attributes throughout a product hierarchy resulting in a product assembly that is associative.

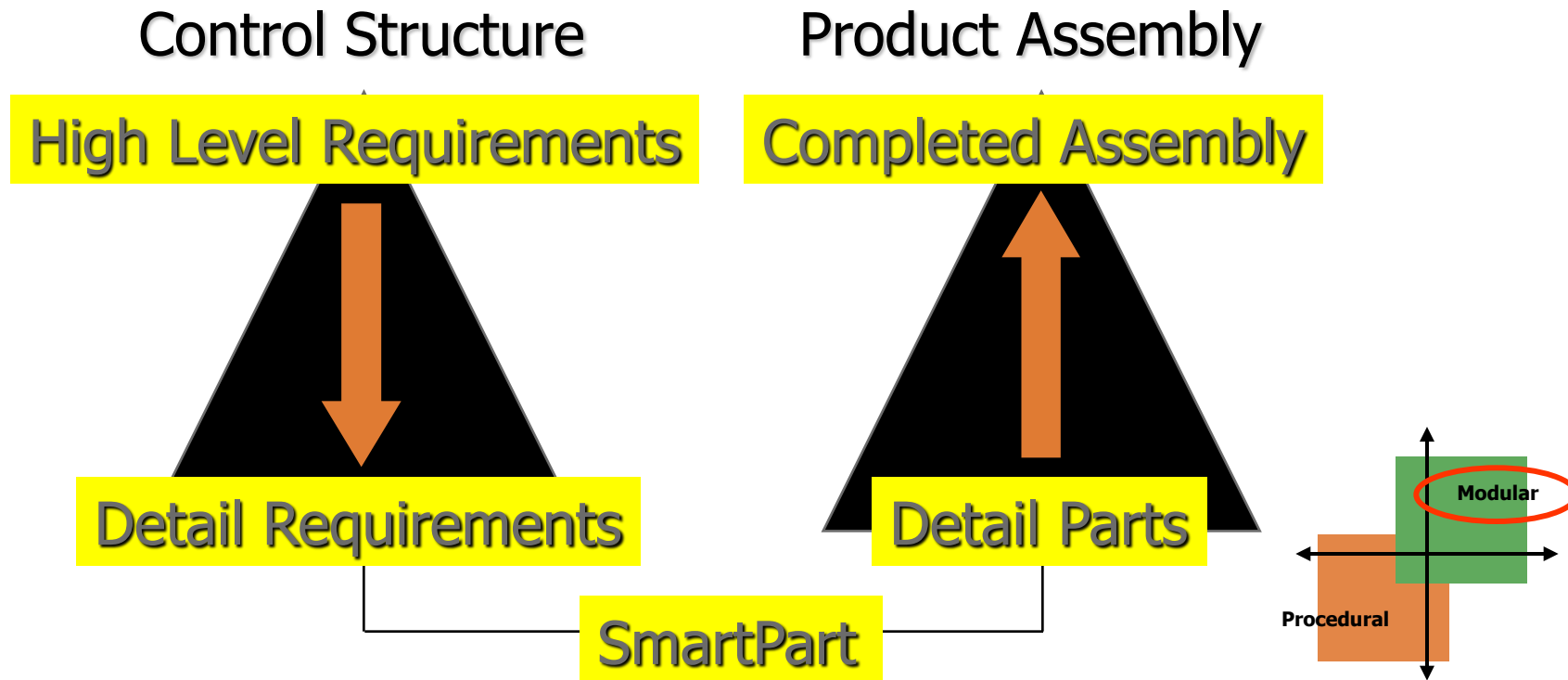

# Modular systems approach

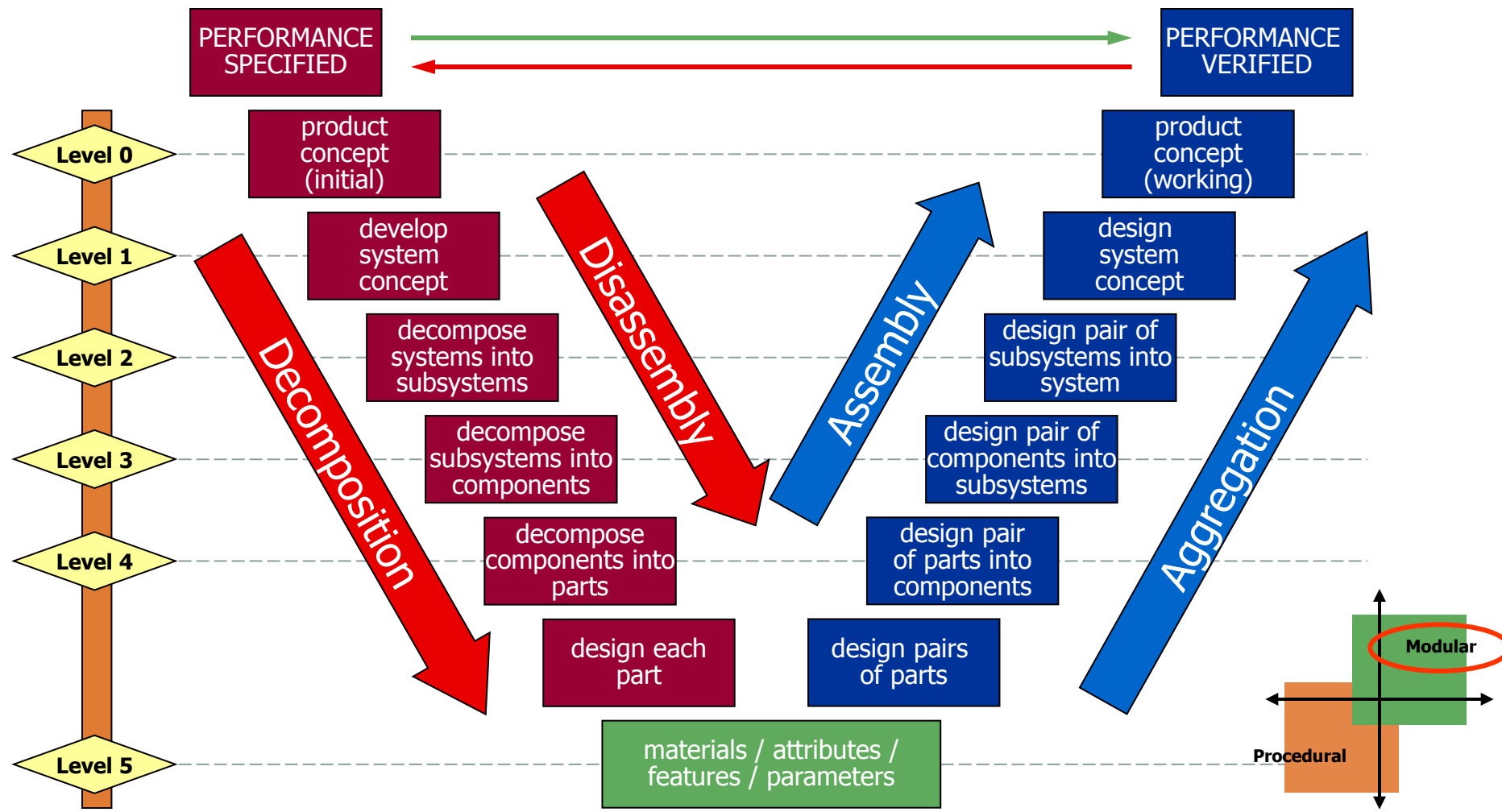

# Modular KBE System

## Product Lifecycle Management (PLM) Implementation

# Open, concurrent KBE system

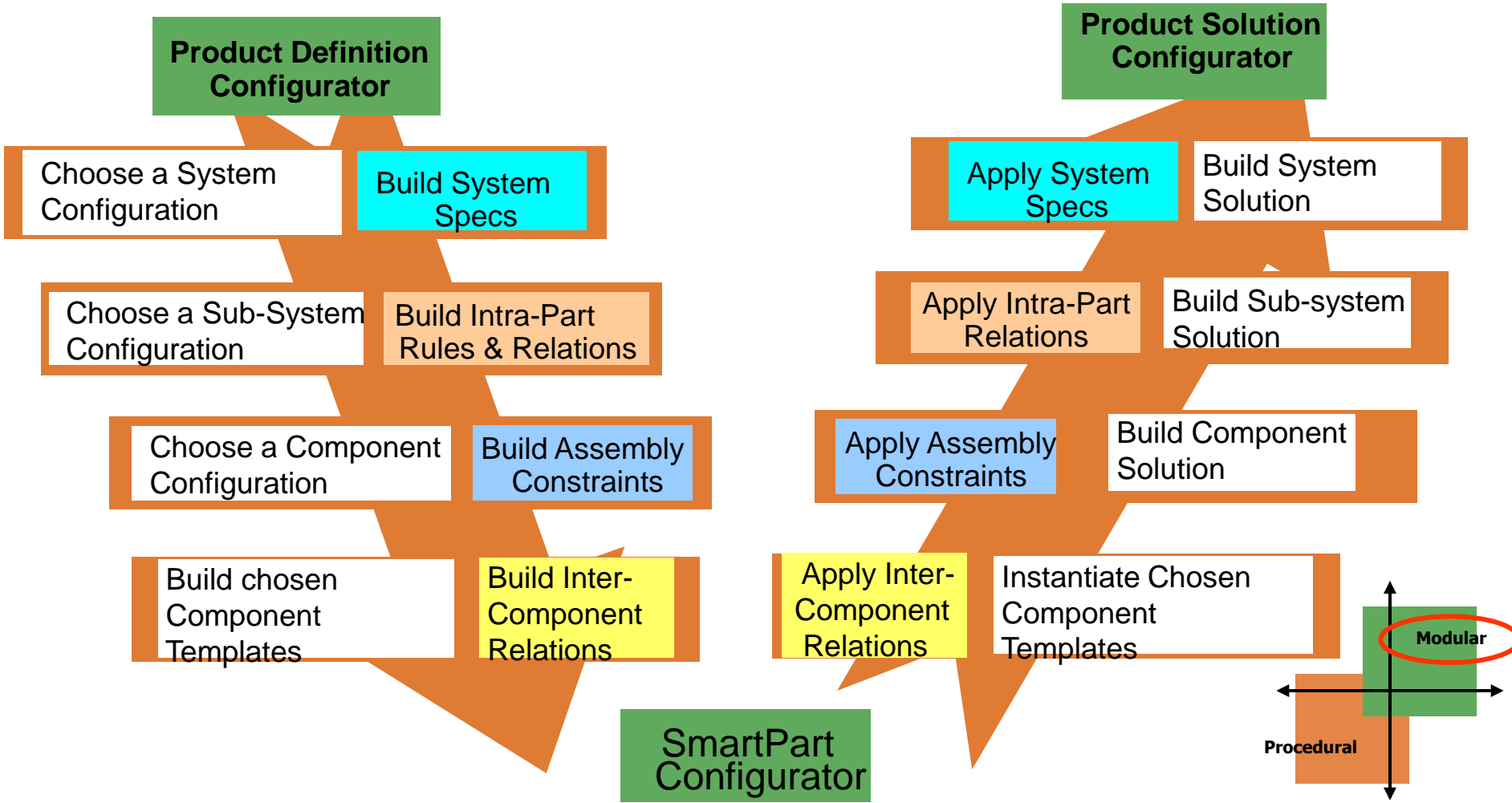



# Merits of modular process

Product Definition Configurator

- Product-Independent
  - Architecture
- Part-Independent
  - Concept
- Tool-Independent
  - Method

Product Solution Configurator

SmartPart Configurator

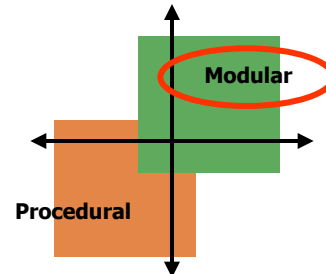

# A CATIA V5 implementation

- System Architecture
  - JustOne system model and common tree structure
- Generative Rule Bodies
  - Rule bodies create more rules dynamically on the tree; asleep until awakened
  - Retrieve templates; no generative geometry
- Internal Linking
  - Two generalized automation methods to pass/exchange information intrapart and interpart

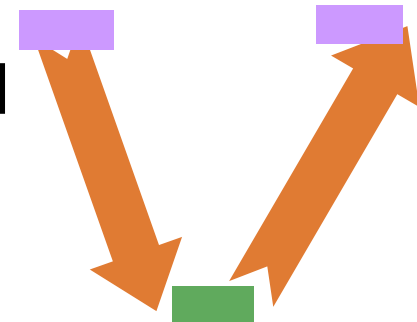



# Specs Definitions (Excel Inputs)

	B	C	D	E	F	G	H	I	J			
	Constraint Name	Type	Value (ir	Constraint Oriena	First Product	First Publication	Second Pro	Second Publication	Compute			
1	CY2PPP_Axial_Coincidence	Coincidence		CatCstOrientUndefined	Cylinder	Cylinder_AxisLine	PPiston	PPiston_AxisLine	Y			
2	CY2REEG_Axial_Coincidence	Coincidence		CatCstOrientUndefined	Cylinder	Cylinder_AxisLine	REEndGland	REEG_AxisLine	Y			
3	CY2REEG_Transverse_Parallel	Parallel		CatCstOrientSame	Cylinder	Cylinder_TransverseLine	REEndGland	REEG_TransverseLine	Y			
4	CY2REEG_Contact	Coincidence		CatCstOrientOpposite	Cylinder	CylinderNutBoreThread_REEndGland_Conta	REEndGland	REEGMiddleRing_Cylinder_ContactPla	Y			
5	CY2EGLockNut_Axial_Coincidence	Coincidence		CatCstOrientUndefined	Cylinder	Cylinder_AxisLine	EGLockNut	EGLockNut_AxisLine	Y			
6	CY2EGLockNut_Transverse_Parallel	Parallel		CatCstOrientSame	Cylinder	Cylinder_TransverseLine	EGLockNut	EGLockNut_TransverseLine	Y			
7	CY2EGLockNut_Contact	Contact		N/A	Cylinder	Cylinder_EGLockNut_ContactFace	EGLockNut	EGLockNut_Cylinder_ContactFace	N			
8	CY2CEEG_Axial_Coincidence	Coincidence		CatCstOrientUndefined	Cylinder	Cylinder_AxisLine	CEEndGland	CEEG_AxisLine	Y			
9	CY2CEEG_Transverse_Parallel	Parallel		CatCstOrientSame	Cylinder	Cylinder_TransverseLine	CEEndGland	CEEG_TransverseLine	Y			
10	Nom PTank Pressure (psi)		175.001		150.001	600.001	& SH	160	600000.001	0	3	
11	Nom STank Pressure (psi)		100.001		150.001	600.001		160	600000.001	0	3	
12	Limit Load Compression (lbf)		120060.001		180060.001	61600.001	NG	160	50000.001	0	3	5c4 4a0
13	Limit Load Tension (lbf)		112140.001		112140.001	61600.001	DRMS	160	600000.001	0	2	
14	Ultimate Load Compression (lbf)		180090.001		180090.001	92401.001		160	600000.001	0.25	3	
15	Ultimate Load Tension (lbf)		168210.001		168210.001	92401.001		160	50000.001	0.25	2.5	
16	Ultimate Load Side (lbf)		800		800	400		160	50000.001	0.25	2.5	
17	Endurance Load Fatigue (lbf)		104400.001		104400.001	51334.001	NG	160	50000.001	0.25	2.5	
18	Proof Supply Pressure (psi)		6000.001		6000.001	6500.001		160	50000.001	0.25	2.5	
19	Burst Supply Pressure (psi)		10000.001		10000.001	10820.001	NG	160	50000.001	0.25	2.5	
20	Impulse Supply Pressure (psi)		6000.001		6000.001	6100.001	NG	160	50000.001	0.25	2.5	
21	Proof Tank Pressure (psi)		4000.001		4000.001	1275.001	NG	160	50000.001	0.25	2.5	
22	Burst Tank Pressure (psi)		6000.001		6000.001	2125.001		160	50000.001	0.25	2.5	
23	Impulse Tank Pressure (psi)		2000.001		2000.001	700.001						
24	Impulse Load Cycles Fatigue		1000.001		1000.001	5000.001						
25	Stroke Nominal (in)		9.487		9.487	8.592						
26	Retract Length (in)		24		34.957	33.394	NG	160	50000.001	0.25	3	
27	Bearing Friction Coeff Proof		0.15		0.15	0.15						
28	Bearing Friction Coeff Burst		0.2		0.2	0.2						
29	Bearing Friction Coeff Fatigue		0.1		0.1	0.1						

# SmartParts Creation

Type: Tandem

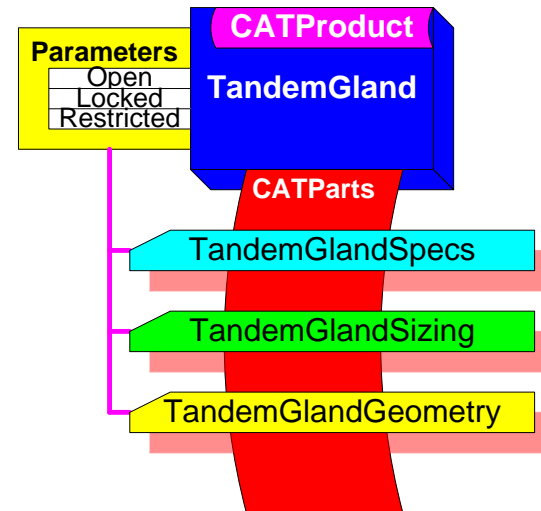
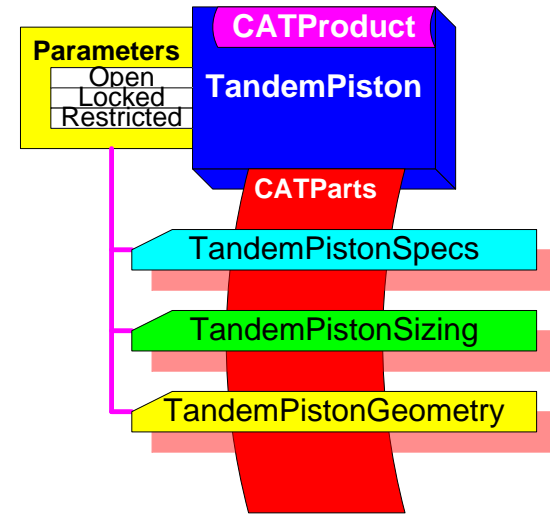
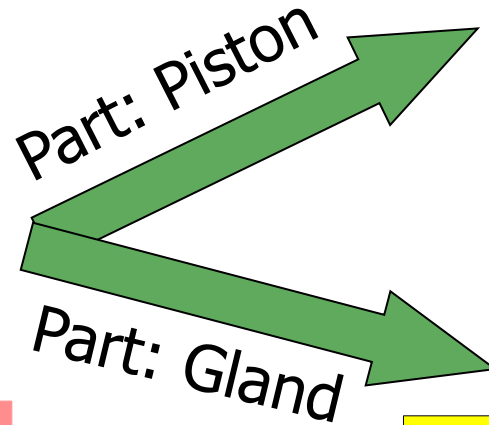
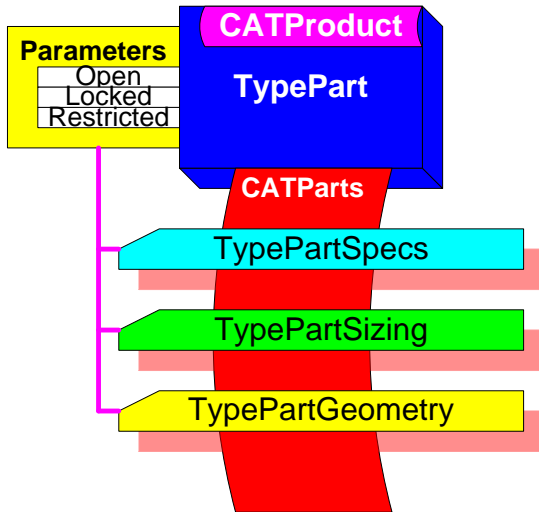

# Achieving a Product Solution

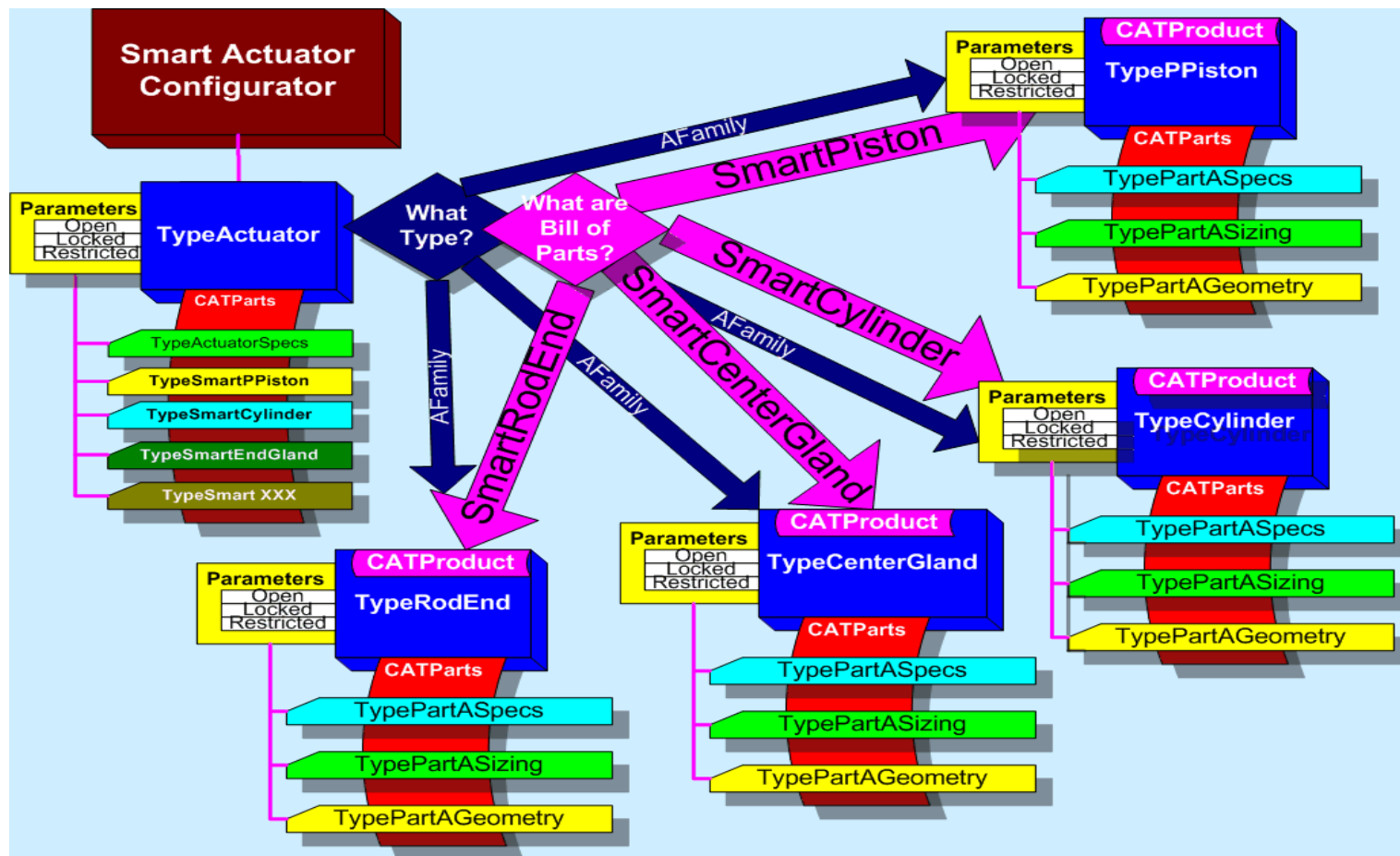

# Inter- & Intrapart communications

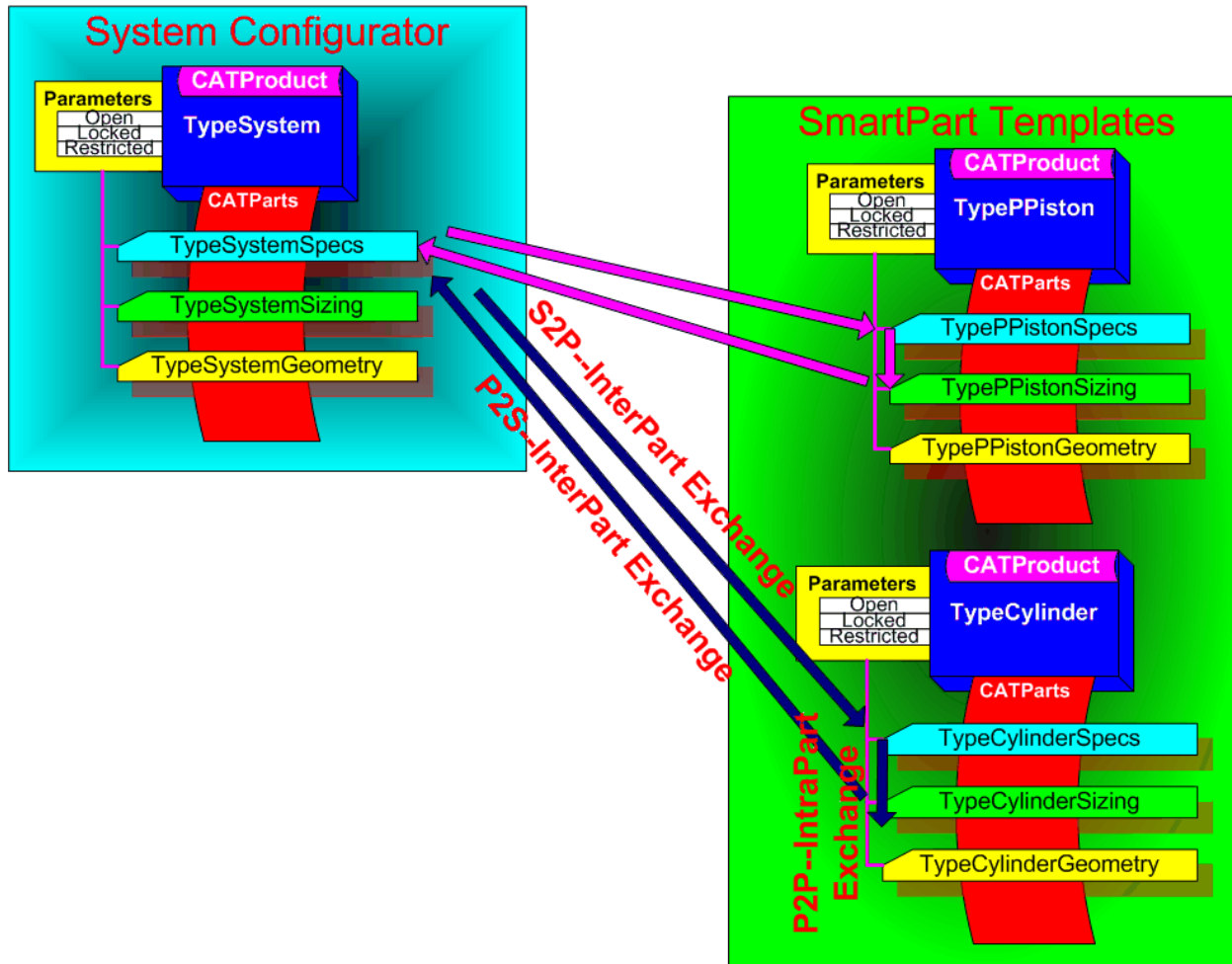

# Demo

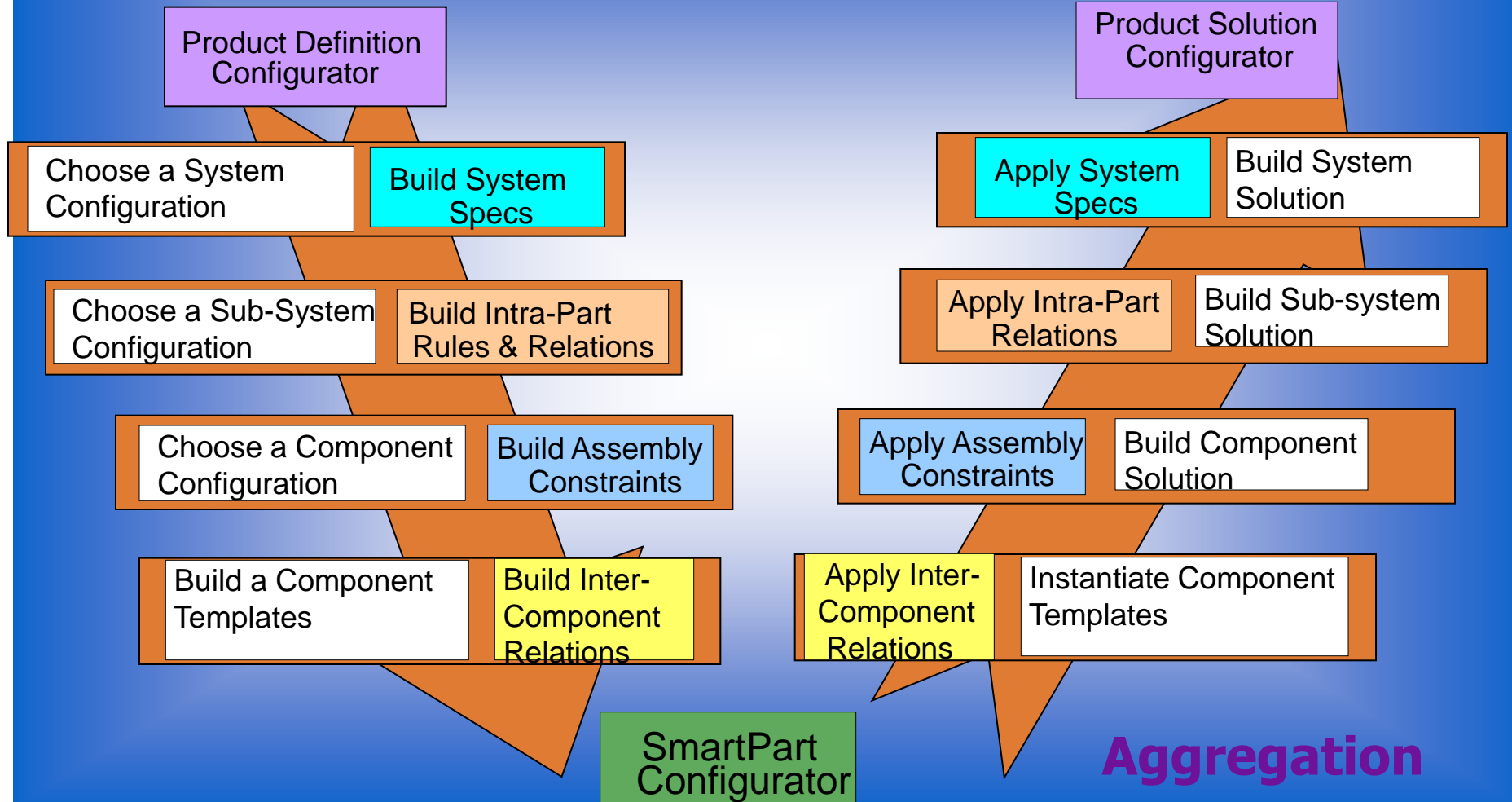

## Demo—Salient points

- Initialize parameters
- SmartParts pulled and Rules added
- Specs parameters & constraints passed from “systems” to “subsystems”, to “components,” to “parts” during “decomposition” and vice versa during “aggregation”
- SmartParts were “instantiated” and constraints satisfied
- Solution is reconfigurable for changing spec requirements

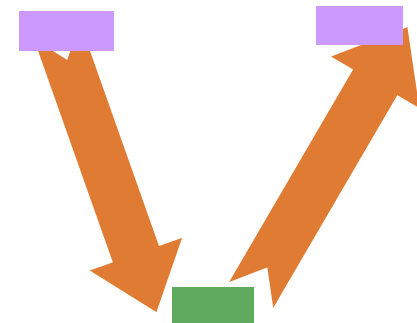



# Engineered design...

...directly from spec

- Good for early program stages (Quick evaluation of various “alternate designs” scenarios)
- Gets you 80% there and you can finish the rest (20%) in native CATIA mode

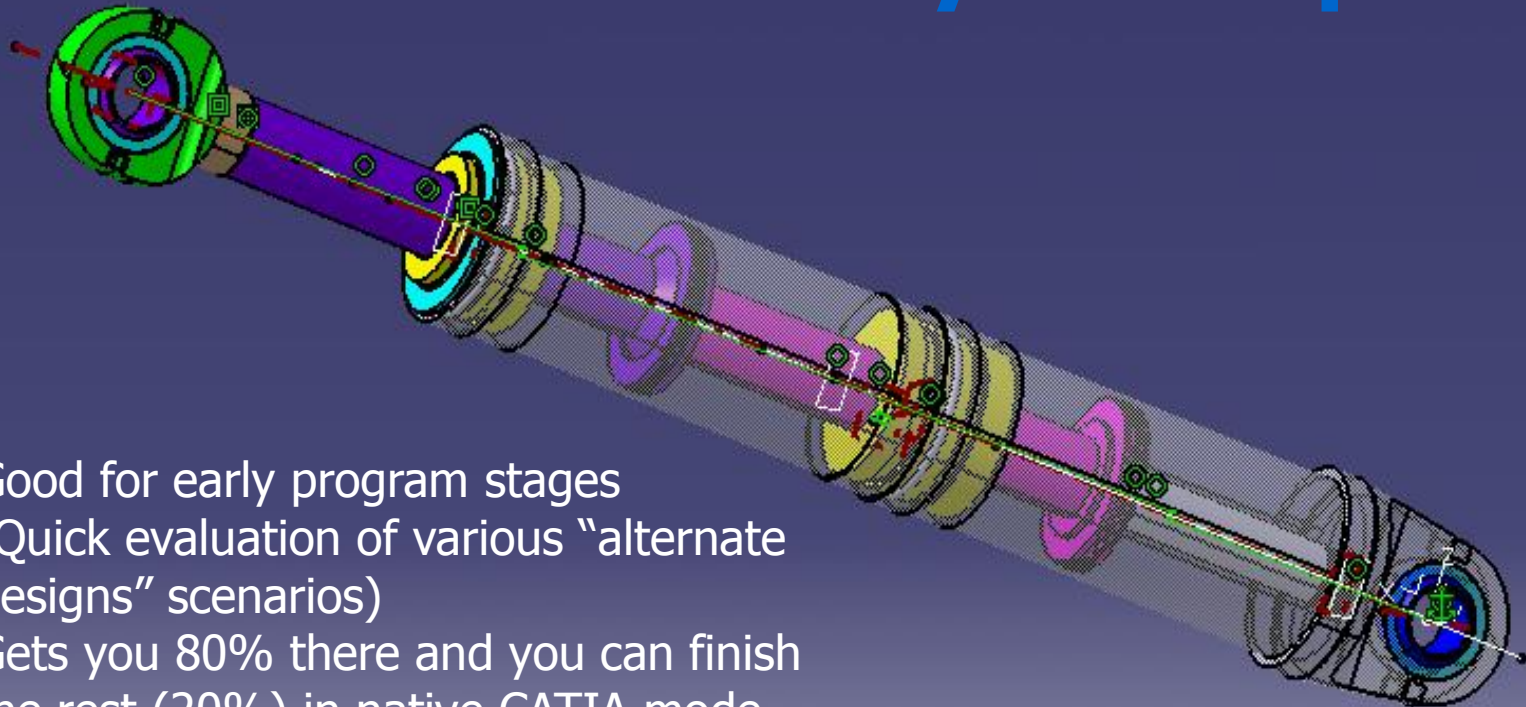

# Engineered design...

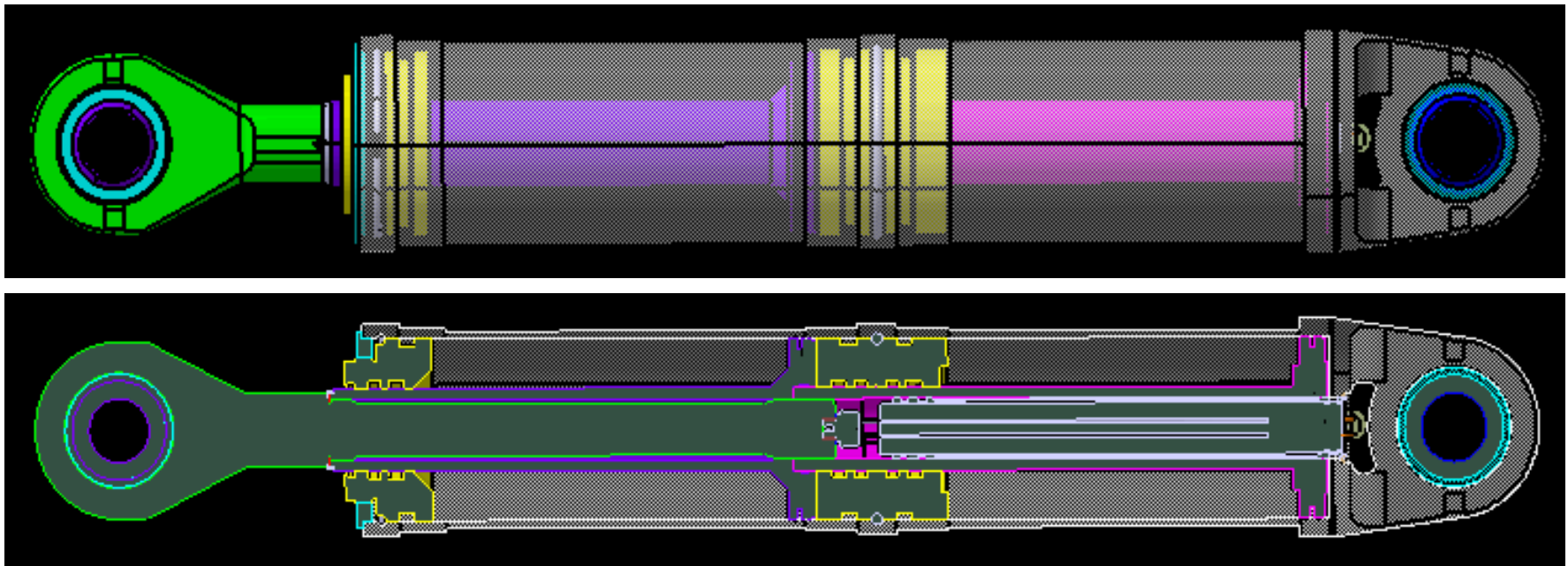

- ***Unbalanced tandem actuator with 4100 psi supply pressure and 9.49 inch stroke.***

**...directly from spec**

# Engineered design...

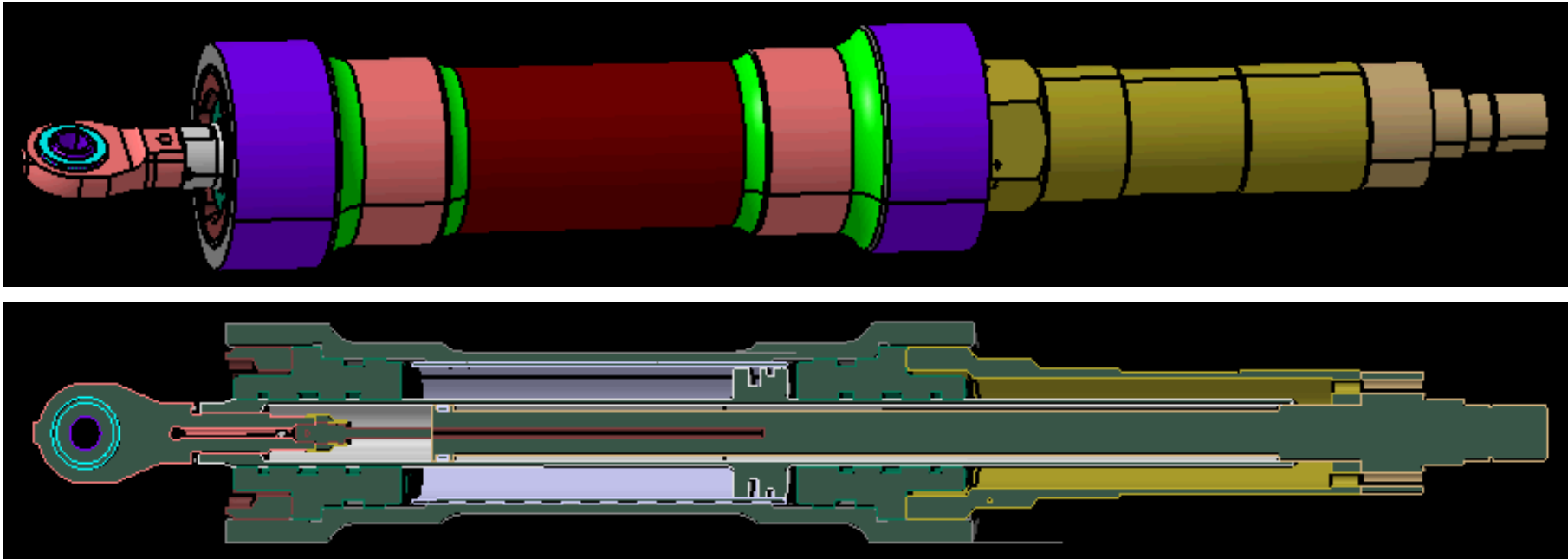

- Balanced simplex actuator with 3050 psi supply pressure and 3.89 inch stroke.

**...directly from spec**

## Key Benefits

- Knowledge resides in one system and reused widely across the enterprise
- Order of magnitude savings (1:10 ~ 1:100)
- Promotes collaboration & knowledge sharing
- Product independent architecture
- Experts now become knowledge-keepers
- Promotes innovations and creativity
- Good for preliminary studies & portfolio mgt
- Knowledge inside, Lean inside, standards inside, analysis inside, best practices inside

## Keys to maximizing KDA gains ...

- KBE has its own life. Think about integration and interfaces. They are big deal for KBE.
- Holistic view of product development process
- Employ a modular, open, and concurrent strategy for building KBE systems
- Think engineering centric versus geometry-centric; analysis driven, geometry is a by-product
- Follow a knowledge management framework for applying KBE

# Questions?

Contact: Brian Prasad

[bprasad@parker.com](mailto:bprasad@parker.com)

Parker Hannifin Corporation  
Aerospace Group  
Control Systems Division—Irvine, CA